

# BOMAG

## REVERSIBLE VIBRATORY PLATES BPR 45/55 D, BPR 55/65 D

### PERFORMANCE DATA

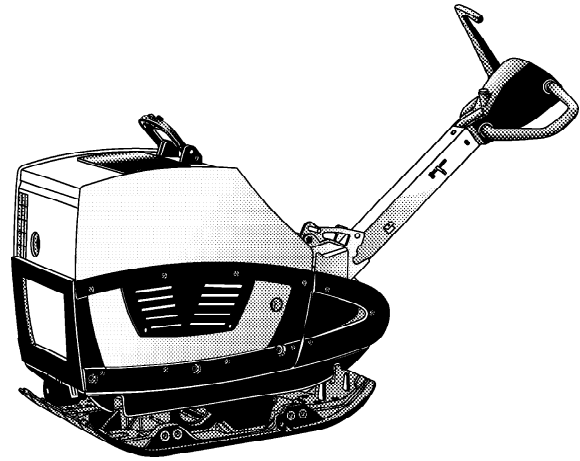

Machine type	Compaction output (m <sup>3</sup> /h) at recommended soil layer thicknesses			
	Rock fill	Gravel, sand	mixed soil	Silt, clay
BPR 45/55 D	-	30-40	25-34	21-28
BPR 55/65 D	-	41-55	36-48	26-35

# BOMAG

# Technical Data

## Shipping dimensions in m3

<b>BPR 45/55 D</b>	0,739
<b>BPR 55/65 D</b>	0,873

## Standard Equipment

- Fully closed engine protection hood made of high-strength grain-refined st
- Hydraulic travel lever adjustment
- 4-times supported, low-vibration steering rod
- Height adjustable steering rod
- Steering rod lockable in transport and working position
- Vibration and throttle regulation on the steering rod
- Highly wear resistant base plate with reinforced edges
- Fully protected V-belt
- Lifetime lubricated vibration bearings
- Reinforced centrifugal clutch
- Large-volume dry air filter with cyclone-type precleaner
- Recoil starter-Automatic decompression
- Multi-functional, foldable single-point lifting facility
- Working width with wear strips 550mm (BPR45/55D)
- Working width with wear strips 650mm (BPR55/65D)
- Automatically adjusting V-belt pulley
- Ramming protection

## Optional Equipment

- Electric starter with warning buzzer ti switch off ignition (+21 kg)
- Tool kit
- Special painting
- Hour meter (El.-starter)
- Vulcolan mat
- Working width with extension plates 750mm
- ECONOMIZER

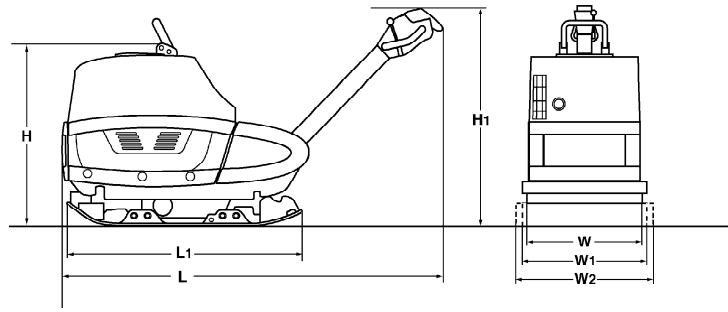

## Dimensions in mm

	H	H1	L	L1	W	W1	W2
<b>BPR 45/55 D</b>	790	800	1700	900	450	550	750
<b>BPR 55/65 D</b>	790	800	1700	900	450	650	750

## Technical Data

### Weights

Operating weight CECE (W)	kg	360	
Operating weight CECE (W1)	kg	375	
Basic weight	kg	370	

### Dimensions

Basic working width	mm	550	650
Working width without extension bars (W)	mm	450	450
Lowest passing height	mm	790	790

### Driving Characteristics

Working speed, max.	m/min	28	28
Max. gradeability (depending on soil conditions)	%	35	35

### Drive

Engine manufacturer		Lombardini	Lombardini
Type		15 LD 440	15 LD 440
Cooling		air	air
Number of cylinders		1	1
Performance ISO 9249	kW	6,6	6,6
Speed	min-1	3.000	3.000
Drive system		mech.	mech.
Fuel		diesel	diesel

### Exciter system

Frequency	Hz	70	66
Centrifugal force	kN	45	55

### Capacities

Fuel	l	5	5
------	---	---	---

Technical modifications reserved. Machines may be shown with options.

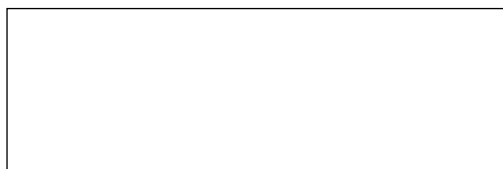

**BOMAG**  
 Hellerwald  
 D-56154 Boppard  
 P.O. Box 5162  
 Tel. (0)6742 - 1000  
 Fax (0)6742 - 3090  
 Fax (0)6742 - 3090

# BOMAG